



RHEEM PREMIER HILINE® 52H SERIES SOLAR WATER HEATER



SOLAR

1-5

PEOPLE
(see table)

180 -
300 L

CAPACITY

7
YEAR

CYLINDER
COLLECTOR
(supply only)
WARRANTY⁵



MODEL NO.
52H300/2SP



FEATURES

- **Complete frost protection** – Heat exchange technology protects the system down to freezing -10°C temperatures
- Available in 180L & 300L tank capacities
- **Space saving design** – a complete roof mounted installation featuring a durable, lightweight stainless steel tank
- **Energy Efficient** – can reduce energy use by up to 65%^{1,2}
- **Booster** – choice of 6-star continuous flow gas boost or electric element back up to provide hot water in any weather condition
- **Low maintenance** – operates using the thermosiphon principle that hot water rises, not requiring electronics or a pump. Premier Hiline® will reliably produce energy efficient hot water
- Mains Pressure delivers full water pressure to all taps at the same time³
- Eligible for STCs⁴
- 7 Year cylinder Warranty⁵

WHY CHOOSE PREMIER HILINE®?

Rheem Premier Hiline® is an indirect solar water heater specifically designed for environments prone to frost. By using the sun's energy as its primary heating source and heating via the thermosiphon principle, this simple system operates without the need for a circulating pump and electronic controller. Premier Hiline® models can also reduce water heating energy consumption by up to 65%^{1,2}.

The range includes both 180L and 300L models, using a multi-riser solar collector design. The whole system is installed on your roof, saving space at ground level.

FROST PROTECTION

Premier Hiline® models feature heat exchange technology, maximising solar gain whilst providing frost protection. Rather than directly heating water, special heat exchange fluid flows through the solar collectors to capture the sun's energy. With its anti-freeze properties, this fluid will prevent freezing in the solar collectors down to -10°C.





RHEEM PREMIER HILINE® 52H SERIES SOLAR WATER HEATER

GAS

ELECTRIC

MODEL		52H180/1SP-G	52H300/2SP-G	52H180/1SP	52H300/2SP
Storage Capacity	L	180	300	180	300
Solar Collectors	SPA2000	1	2	1	2
Booster Type		Gas – Remote	Gas – Remote	Electric	Electric
Boost Capacity	L	26L/min	26L/min	90	150
People Per Household		1-3	2-5	1-2	2-5
Dimensions & Specifications					
Height (A)	mm	2520	2520	2520	2520
Width (B)	mm	1495	2198	1138	2198
Depth (C)	mm	563	563	563	563
Collector Depth (D)	mm	1996	1996	1996	1996
Collector Width (E)	mm	1043	2114	1043	2114
Collector Height (F)	mm	82	82	82	82
Weight Empty – Tank	kg	53	78	53	78
Weight Full – Tank	kg	231	373	231	373
Weight Empty – Solar Collectors	kg	50	100	50	100
Weight Full – Solar Collectors	kg	54	108	54	108

180 Litre Premier Hiline

300 Litre Premier Hiline

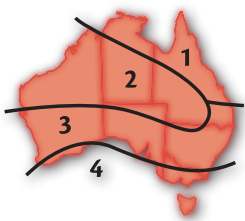
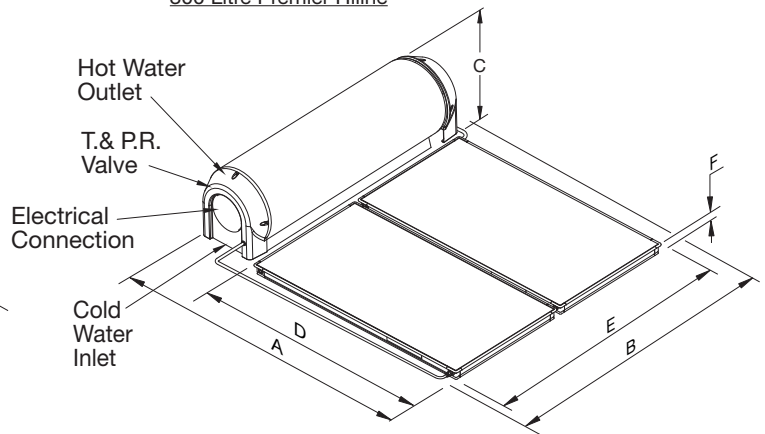
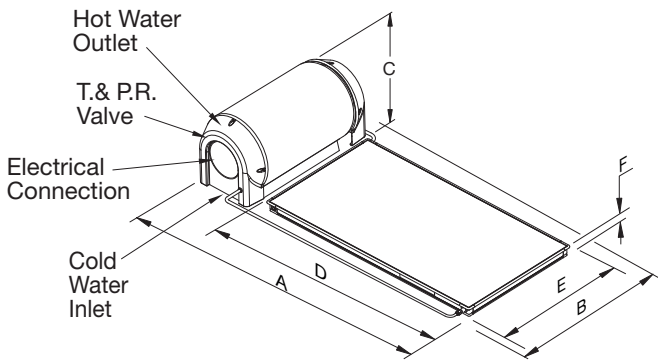

STCs

Small-scale Technology Certificates (STCs) are a financial benefit to encourage the installation of solar water heaters provided under a Federal Government legislated scheme.

This map shows the climate Zones within Australia which will define the number of STCs allocated to an approved solar water heater. Your installation may be eligible.⁴

To claim your STC entitlement, simply complete the STC Assignment form. Visit www.rheem.com.au/rebates to download the STC Assignment form.

¹ Energy reduction of up to 65% based on Australian Government Approved TRNSYS simulation modelling of a Rheem 52H300/2SP using a medium load in Zone 3 and applies when replacing an electric water heater.

² Any financial savings will vary depending upon type of Rheem Solar system installed, orientation and inclination of the solar collectors, type of water heater being replaced, hot water consumption and fuel tariff. Maximum financial savings off your hot water bill are achievable when replacing an electric water heater on continuous tariff.

³ Electric boost models only.

⁴ Eligibility criteria apply.

⁵ Warranty Conditions. 7 years supply on cylinder, 5 years supply on solar collectors, 1 year labour on cylinder and solar collectors, 1 year supply and labour on other parts. Conditions apply. See the Rheem warranty set out in the Owner's Guide & Installation Instructions or view at www.rheem.com.au/warranty Phone 131 031 for details.

Materials and specifications correct as on 1st March 2019. Rheem Australia reserves the right to change product specifications without any prior notification.

[®] Registered Trademark of Rheem Australia Pty Ltd.

[™] Trademark of SAI Global.



Rheem Australia Pty Ltd.

1 Alan Street, Rydalmere, New South Wales 2116, Australia
PO Box 7508, Silverwater, New South Wales 2128, Australia.

