

Electric



**AquaMAX**<sup>®</sup>  
Water Heaters



“AquaMAX electric water heaters... giving you more in hot water”

VITREOUS ENAMEL ELECTRIC WATER HEATERS

# Stay in hot water with AquaMAX.

Award winning AquaMAX high efficiency electric water heaters provide your family with all the hot water they need.

AquaMAX mains pressure electric water heaters are built using the latest technology and with a cylinder warranty<sup>1</sup> up to 10 years. They are available in sizes to suit most applications.

AquaMAX electric water heaters are made for Aussie conditions, to suit both metro and regional areas.

## FAMILIES BIG AND SMALL

AquaMAX electric mains pressure water heaters provide families big and small with reliable hot water. AquaMAX inhouse factory testing ensures every new system we build meets our exacting standards whether it's installed indoors or outdoors. You can also take advantage of lower cost off-peak tariffs for added savings on your energy bills.<sup>2</sup>

## HOW DO WE MAKE THEM ACHIEVE OUR STANDARD?

After our cylinders have been fully welded, we apply a high quality enamel coating to create our enamel lining. Combined with a sacrificial anode and protected by a steel casing with rounded edges, every AquaMAX electric water heater is backed by a 10 or 7 year cylinder warranty.<sup>1</sup>

## Electric Specifications

Number of People Served	
- Continuous/Time of Use Tariff	
- Off peak/night rate	
Hot Water Delivery	Litres
Storage Capacity	Litres
Boost Capacity (Twin Element)	Litres
Weight packaged (approx)	kg
Maximum Loading	Watts
Heating Element Upper	Watts
Heating Element Lower	Watts



400 Litre			315 Litre				250 Litre				160 Litre Squat		160 Litre			125 Litre			80 Litre	50 Litre
991400G7	991400G8	992400G8	991315G7	991315G8	992315G7	992315G8	991250G7	991250G7/BL	991250G8	992250G7	9W1160G4	9W1160G5	981160G4	981160G5	981160G7	981125G4	981125G4/BL	981125G7	981080G7	991050G7
5-9			4-6				3-5				2-4		2-4			2-3			1-2	1
4-6			2-4				1-3				-		-			-			-	-
400			315				250				160		160			125			80	50
410			325				270				175		165			135			90	53
-	90	-	50				-				50		-			-			-	-
120			97				82				58		56			44			32	26
3600	4800	4800	3600	4800	3600	4800	3600	3600	4800	3600	1800	2400	1800	2400	3600	1800	1800	3600	3600	3600
-			4800				-				3600		-			-			-	-
3600	4800	4800	3600	4800	3600	4800	3600	3600	4800	3600	1800	2400	1800	2400	3600	1800	1800	3600	3600	3600

## Specifications

	991400	991315	991250	9W1160	971160	981125	981080	991050
Voltage (single phase)	240Vac	240Vac	240Vac	240Vac	240Vac	240Vac	240Vac	240Vac
Maximum Supply Pressure								
with expansion control valve (ECV)	680 kPa	680 kPa	680 kPa	680 kPa	680 kPa	680 kPa	680 kPa	680 kPa
without expansion control valve (ECV)	800 kPa	800 kPa	800 kPa	800 kPa	800 kPa	800 kPa	800 kPa	800 kPa
Pressure & Temp Relief Valve	1000 kPa	1000 kPa	1000 kPa	1000 kPa	1000 kPa	1000 kPa	1000 kPa	1000 kPa
ECV setting	850 kPa	850 kPa	850 kPa	850 kPa	850 kPa	850 kPa	850 kPa	850 kPa
Thermostat setting (Maximum)	70°C	70°C	70°C	70°C	70°C	70°C	70°C	75°C
Hot & Cold Water connection	Rp 3/4" Female	Rp 3/4" Female	Rp 3/4" Female	Rp 3/4" Female	Rp 3/4" Female	Rp 3/4" Female	Rp 3/4" Female	Rp 3/4" Female
Warranty (Cylinder) <sup>1</sup>	10 years*	10 years*	10 years*	10 years*	10 years*	10 years*	10 years*	7 years <sup>1</sup>
Warranty (Parts & Labour) <sup>1</sup>	1 year	1 year	1 year	1 year	1 year	1 year	1 year	1 year
Protection rating	IP24	IP24	IP24	IP24	IP24	IP24	IP24	IP24

Due to constant product improvements, the specifications are subject to change without notice.

1. Conditions apply. Full warranty details available on request from AquaMAX, call Toll Free 131 031, see the warranty set out in the Owner's Guide and Installation Instructions or view at [www.aquamax.com.au](http://www.aquamax.com.au)

\* 10 year cylinder warranty applies to – 991400, 992400, 991315, 992315, 991250, 992250, 981160, 981125, and 981080 models.

<sup>1</sup> 7 year cylinder warranty applies to – 991050 model.

2. Please refer to your energy provider.





## 50L ELECTRIC

SMART THINGS COME IN SMALL PACKAGES

Designed to be everything required for tight installations.

We solved access problems by providing dual handed fittings and relocating all the service outlets to the front.



## 160L SQUAT

A BIG TANK MADE FOR SHORT SPACES

The AquaMAX commitment to innovation continues with the 160 litre electric Squat. An electric water heater that brings larger capacity to awkward indoor spaces. With dual inlets and outlets, the 160 litre electric Squat brings reliable delivery in a smarter package.



## 250L-400L ELECTRICS

BIG DELIVERY, LOWER RUNNING COSTS

The AquaMAX large electric water heater range provides an option to take advantage of lower cost off-peak tariffs.<sup>2</sup>

Built with dual inlets and outlets (like the rest of the range), the 250-400 litre electric range is available in single or twin element models.

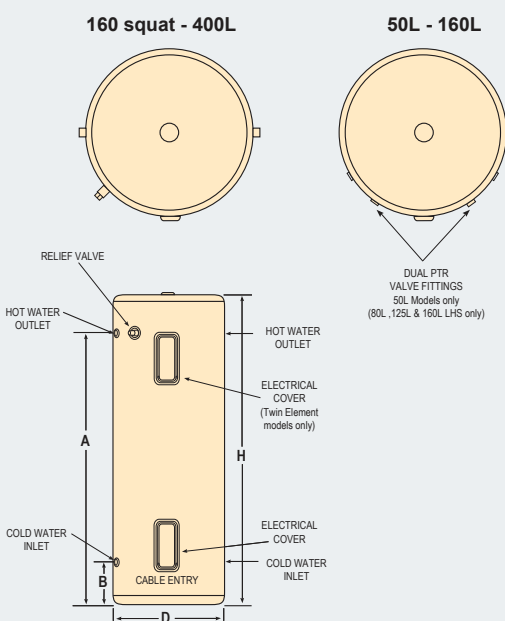

Water Heater Dimensions (mm)

	H	A	B	D
991050	695	539	142	400
981080	875	669	194	460
981125	1250	1046	194	480
981160	1550	1350	200	480
9W1160	965	755	113	640
991250/992250	1395	1182	73	640
991315/992315	1640	1430	113	640
991400/992400	1840	1600	121	690



Rheem Australia Pty Ltd (ABN 21 098 823 511)  
 National Office: 1 Alan Street Rydalmere NSW 2116  
 National Sales Phone: 132 552  
 For more information visit [www.aquamax.com.au](http://www.aquamax.com.au)

© 2023 Rheem Australia Pty Ltd. AquaMax and the AquaMax logo are registered trade marks in Australia of Rheem Australia Pty Ltd. Materials, product data and specifications subject to change without notice.